

Seismic Switch, Inc.
2125 Magnolia Ave.
Petaluma, Ca. 94952
707-763-9993 Fax 763-9994

Seismic Switch Battery Back-up Revision B
January 1, 2008

The most important new feature of the Rev B unit is the red LED that lights up when the battery level is low. When that LED is lit, batteries should be replaced ASAP. If A.C. power is lost when the red LED is on, the unit will go into seismic trigger mode.

The batteries should be installed when A.C. power is available to the board.

Operation: Depending on the presence of line power the backup unit operates in one of two modes:

a) Without power applied, two lithium batteries provide 5VDC to trigger a latching relay through the **normally open** contacts on the earthquake trigger devices. To extend battery life the trigger LED indication circuit, the replace battery LED, and the normally closed input switching circuits are all disabled.

b) When line power is available the batteries are disconnected from the circuit and the indication light circuits become active. The **normally closed** input switch circuits also become active, providing a fail-safe mechanism in case of a faulty wiring connection.

NOTE: Testing of the earthquake detection system should be done both with and without line power applied. This will insure that both the normally open and normally closed switch contacts on the seismic sensor are working properly.

Trigger Indication: The red LED will light when the latching relay has triggered and power is applied.

Input terminals: Two input terminals from the seismic sensor are provided - one for normally closed switch contacts and one for the normally open switch contacts.

When using both horizontal and vertical motion detectors, the normally open contacts are connected in **parallel** between the NO and COM input terminals. The normally closed contacts are each connected individually between an NC terminal and the COM input terminal.

When using either a horizontal or vertical detector alone, the normally closed contact is connected between one of the NC input terminals and the COM input. The normally open switch contact is connected between the NO input terminal and the COM input terminal. *The remaining NC input terminal must be jumpered directly to the COM input terminal.*

Output contacts: The output relay contacts are UL rated for 0.6 A at 125 VAC or 110 VDC. When the unit is triggered (trigger LED on) connection is made between the COM and NC output terminals.

Battery replacement: The batteries are standard manganese oxide lithium 2/3A cylinder batteries. Replacement batteries should be equivalent to the following:

Duracell: DL2/3AL Panasonic: BR2/3A

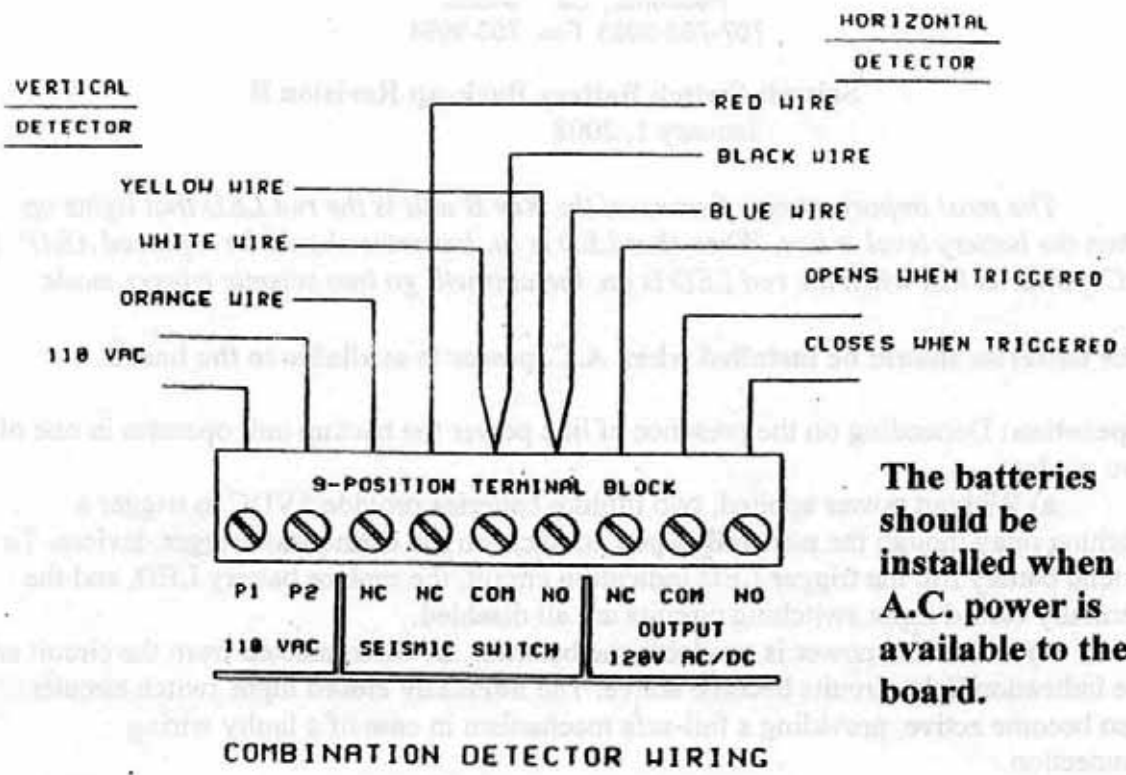

The batteries should be installed when A.C. power is available to the board.

